

纸板破碎机 Cardboard Shredder

机器应用

专门用于废纸, 纸板或纸箱的破碎。

Usage

Specially used for shredding waste paper, cardboard or carton.



Diagram (Model XPS-1450)

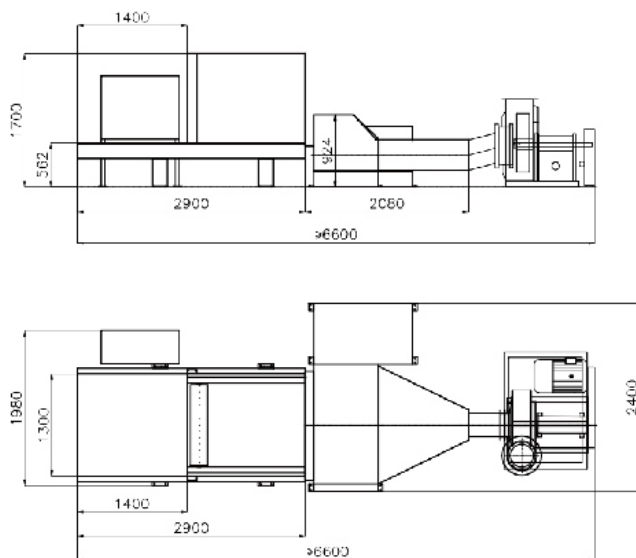

参数 Specifications

型号 Model	XPS-1450
最大入料宽度 Maximum Feeding Width	1450mm
送纸电机功率 Paper Conveying Motor Power	2.2kw
压料输送机功率 Waste Compressing Conveyor Motor Power	1.5kw
破碎纸电机功率 Paper Shredding Motor Power	22kw
风机功率 Shredding Fan Power	18.5kw
处理量 Handling Capacity	2000kgs/h
设备重量 Machine Weight	3000kgs
机器尺寸(含碎纸风机) Machine Size(including size of shredding fan)	6600*2400*1700mm

机器特点

- 采用高强度输送机送料
- 采用大扭力齿轮减速机
- 采用52组高强度白钢刀具，耐用，方便更换
- 采用安全设计，严格保护操作者安全
- 安全设计符合欧洲标准
- 采用德国技术

Features

- Equipped with High-Strength conveyor for feeding
- Equipped with gear reducer of strong torque force
- Equipped with 52 pieces of strong white-steel blades, durable and convenient for changing
- Equipped with safety design to protect the operators
- With European standard safety design
- With German technology