

大中型闭口卧式打包机

Large-sized and Medium-sized Semi Automatic Balers with Closed Gate

机器应用

专门用于塑料薄膜, 塑料瓶, 塑料筐, 废弃电脑壳, 废纸, 废旧纸板, 纸箱, 海绵等松散物的压缩打包。

Usage

Specialized in recycling and compressing the loose materials like plastic film, PET bottles, plastic pallets, waste computer shell, waste paper, cartons, cardboards trims/scraps, foam etc.



Bale Size (Model XTY-1000WB11085)

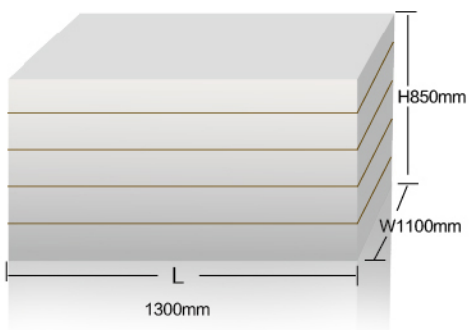
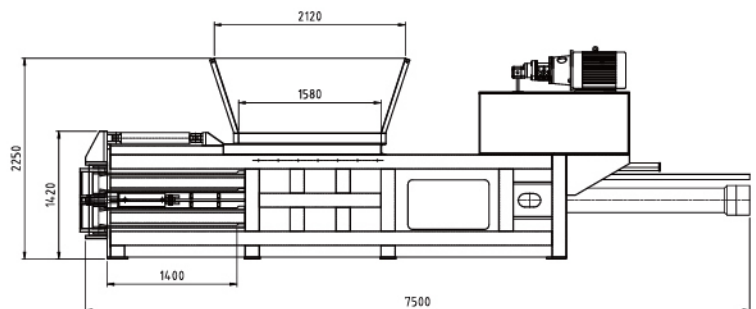

Diagram (XTY-1000WB11085)



机器特点

- 闭口式结构，使得包打的更紧
- 高强度出包门，自动开关门，液压锁门，使操作更便捷
- 合理的双剪式刀片设计，提高了切纸效率，延长刀片的使用寿命
- 独特的防滑落设计，避免梯形包的出现，使包块更美观
- 主油缸采用炮耳支架及球端面设计，可消除作用在主轴上的扭矩，显著延长油封寿命
- 压车经过龙门铣床加工，确保运动时的精度
- 本机采用原装台湾进口液压阀，使机器更安全耐用
- 无需特殊的场地基础设施，使安装简单容易

Features

- Heavy duty close-gate design for more tighter bales
- Hydraulic locked gate ensures more convenient operation
- Unique double-cutting design of cutters improves the cutting efficiency and lengthens the lifespan of the cutters
- Particular anti-slide design of the machine makes nicer bales
- Unique trunnion-mounted frame and ball-end joint design for the main cylinder avoid the torque on the rod, which lengthens the lifespan of the seals
- The press heads are specially processed by planomiller, ensures the precise running of the ram
- Use high quality hydraulic valves from Taiwan, ensures the stable running of the machine
- The heavy duty machine body makes sure only flat ground is required by the installation

参数 Specifications

| 型号 Model | XTY-300WB7070 | XTY-400WB7280 | XTY-600WB10080 | XTY-1000WB11085 | XTY-1000WB110110 |
|---|---------------------------|---------------------------|---------------------------|---------------------------|---------------------------|
| 压力 Pressure | 30tons | 40tons | 60tons | 100tons | 100tons |
| 主电机功率 Main Motor Power | 11kw | 11kw | 15kw | 30kw | 30kw |
| 冷却方式 Cooling System | N/A | air cooler/water cooler | air cooler/water cooler | air cooler/water cooler | air cooler/water cooler |
| 循环时间 (空载) Cycle Time (unload) | 27s | 19s | 23s | 36s | 42s |
| 油箱尺寸 Oil Reservoir | 240L | 240L | 380L | 1460L | 1600L |
| 捆包道数 Number of Belting | 3lines | 4lines | 4lines | 4lines | 5lines |
| 捆包铁丝规格 Wire Size | Ø 2.4-2.7 | Ø 2.4-2.7 | Ø 2.7-3.0 | Ø 3.0-3.2 | Ø 3.0-3.2 |
| 加料口尺寸 (L*W) Feed Opening Size (L*W) | 700*690mm | 1000*700mm | 1200*980mm | 1400*1050mm | 2000*1050mm |
| 压缩腔尺寸 (L*W*H) Chamber Size (L*W*H) | 1700*690*690mm | 2200*700*780mm | 2400*980*780mm | 3000*1050*830mm | 4000*1050*1050mm |
| 包块尺寸 (L*W*H, L可调) Bale Size (L*W*H, L can be adjustable) | 900*700*700mm | 1000*720*800mm | 1000*1000*800mm | 1300*1100*850mm | 1600*1100*1100mm |
| 打包密度 (OCC) Bale Density (OCC) | 400-500kgs/m ³ | 400-500kgs/m ³ | 450-550kgs/m ³ | 500-600kgs/m ³ | 500-600kgs/m ³ |
| 产量 (大概/与原材料密度和 操作人员的速度决定) Throughput (approx./ depend on the raw material density and the skill of the operators) | 0.5-1ton/h | 0.5-1ton/h | 1-2tons/h | 1.5-3tons/h | 2-6tons/h |
| 机器重量 Machine Weight | 4tons | 4tons | 5.2tons | 12tons | 18tons |
| 机器外观尺寸 Machine Overall Dimension | 4200*1100*1900mm | 5500*1100*2000mm | 6100*1400*2000mm | 7450*1600*2300mm | 8200*1600*3500mm |
| 送料装置 Feeding Device | cyclone/belt conveyor | cyclone/belt conveyor | cyclone/iron conveyor | cyclone/iron conveyor | cyclone/iron conveyor |

输送机 Conveyor

| | | | | | |
|---------------------------|-----------------|------------------|------------------|-------------------|-------------------|
| 有效宽度 Feeding Width | 600mm | 1000mm | 1000mm | 1300mm | 2000mm |
| 速度 Speed | 12m/min | 12m/min | 12m/min | 12m/min | 12m/min |
| 功率 Power | 5.5kw | 2.2kw | 5.5kw | 7.5kw | 7.5kw |
| 重量 Weight | 1.0tons | 1.2tons | 5tons | 7tons | 10tons |
| 外观尺寸 Overall Dimension | 4500*800*2000mm | 5000*1200*2500mm | 9000*1300*3800mm | 10500*1900*4700mm | 10500*2200*4700mm |

大中型闭口卧式打包机

Large-sized and Medium-sized Semi Automatic Balers with Closed Gate

