

半自动开口打包机

Semi-Automatic Baler With Open Gate

机器应用

专门用于废纸，废旧纸板，塑料废膜等松散物的压缩打包机

Usage

Widely applied by cartons/cardboards, plastic film packaging plants, printing and paper factories etc. For recycling waste cardboard/cartons trims, paper, scraps, plastic film etc.

Diagram (Model XTY-400WS7280)

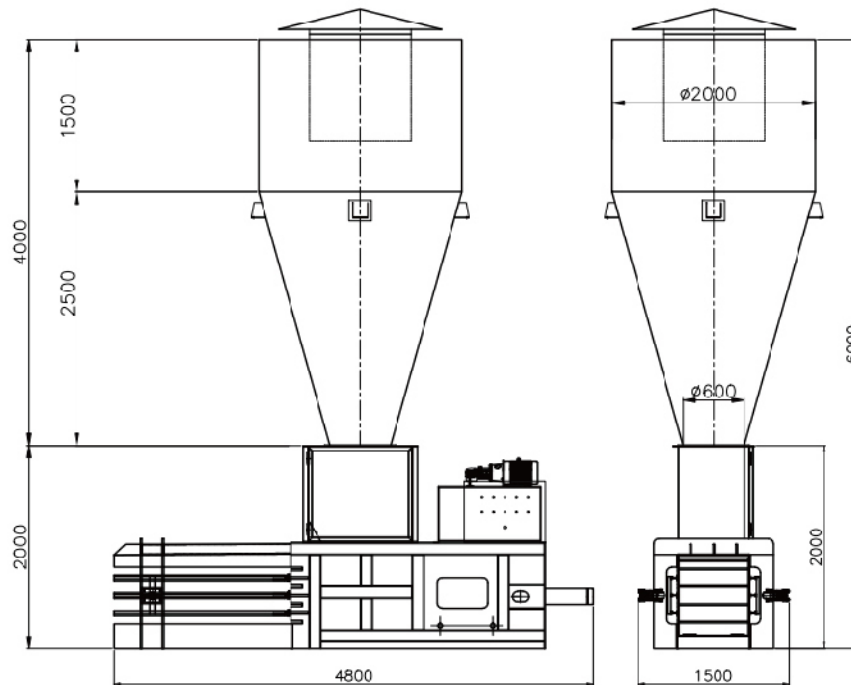

Bale Size (Model XTY-400WS7280)

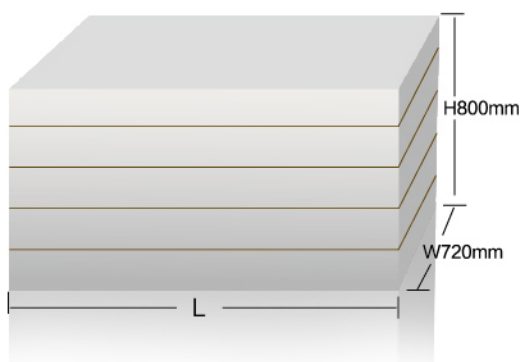

机器特点

- 开口式结构，使出包方便快捷，提高工作效率
- 可配强力吸风设备，使吸纸速度更快
- 合理的双剪式刀片设计，提高了切纸效率，延长刀片的使用寿命
- 独特的防滑落设计，避免梯形包的出现，使包块更美观
- 主油缸采用炮耳支架及球端面设计，可消除作用在主轴上的扭矩，显著延长油封寿命
- 压车经过龙门铣床加工，确保运动时的精度
- 本机采用原装台湾进口液压阀，使机器更安全耐用
- 无需特殊的场地基础设施，使安装简单容易



Features

- Open-end design for conveniently ejecting the bales out
- Powerful cyclone is optional for rapid sucking scraps/trims from the corrugation production line
- Unique double-cutting design of cutters improves the cutting efficiency and lengthens the lifespan of the cutters
- Particular anti-slide design of the machine makes nicer bales
- Unique trunnion-mounted frame and ball-end joint design for the main cylinder avoid the torque on the rod, which lengthens the lifespan of the seals
- The press heads are specially processed by planomiller, ensures the precise running of the ram
- Use high quality hydraulic valves from Taiwan, ensures the stable running of the machine
- The heavy duty machine body makes sure only flat ground is required by the installation

参数 Specifications

型号 Model	XTY-400WS7280	XTY-1000WS110125-75
主油缸尺寸 Main Cylinder Size	Ø125	Ø220
主电机功率 Main Motor Power	11kw	55kw
冷却方式 Cooling System	N/A	Air cooler/water cooler
循环时间 (空载) Cycle Time (unload)	20s	23s
油箱尺寸 Oil Reservoir	240L	1800L
捆包道数 Number of Belting	4lines	5lines
捆包铁丝规格 Wire Size	Ø2.4-2.7	Ø2.4-2.7
加料口尺寸 (L*W) Feed Opening Size (L*W)	1000*690mm	2080*1076mm
压缩腔尺寸 (L*W*H) Chamber Size (L*W*H)	1200*720*800mm	2400*1076*1250mm
包块尺寸 (L*W*H) Bale Size (L*W*H, L can be adjustable)	L*720*800mm	L*1100*1250mm
打包密度 (OCC) Bale Density (OCC)	350-450kgs/m ³	350-450kgs/m ³
产量 (大概/与原材料密度和操作人员的速度决定) Throughput (30-60kgs/m ³)	0.5-1ton/h	5-8tons/h
机器重量 Machine Weight	5tons	16.5tons
机器外观尺寸 Machine Overall Dimension	4800*1500*2000mm	9100*2500*4300mm
送料装置 Feeding Device	cyclone / conveyor	cyclone / conveyor